

TVD-M2225V-2-P

2 MPX HD Indoor IR Dome ONVIF/PSIA

Overview

TruVision™ IP and IP megapixel IR compact dome cameras bring state-of-the-art, high definition pictures to the mass video surveillance market. With a wide variety of camera resolutions ranging from standard resolution through 5 megapixel, these IP cameras represent a flexible video surveillance device to meet any need. Equipped with advance technology and signal processing capabilities, the effectively capture video under challenging conditions.

Compression & streaming

These TruVision cameras utilize H.264 compression technology with dual-stream capability, making it easy to manage the camera's bandwidth usage.

Fully designed to adhere to PSIA and ONVIF open communication standards as well as supporting a CGI command set, these cameras allow for simple integration into any IP system. Video streams can be set for high or low bandwidth and images can be streamed for live viewing or sent to a designated recording location.

Additional Features

Featuring an integrated browser and available SDHC memory card storage capabilities, TruVision IP and IP Megapixel cameras simplify remote, live monitoring/playback of edge-recorded video and audio. Recording on the memory card also provides a level of redundancy in case of unforeseen network disruptions.

Form Factor

The IR compact dome version of the TruVision IP & Megapixel range provides a vandal proof IR indoor solution up to five megapixel. Available with a wide range of appropriate brackets and wall mounts, these cameras can provide a solution to the most advanced of needs. Typical application areas are places where crisp images are required, even in pitch black darkness, such as retail, banking, airports, gaming or mass transit.



Details

- Maximum Resolution: 1600x1200 @ 12.5 fps
- Maximum Real Time Resolution: 1280x960 @ 25 fps (HD)
- Designed to PSIA and ONVIF open standards
- H.264 compression with dual streaming functionality
- Edge recording up to 32GB SDHC card
- 1/3" CMOS image sensor
- Motorized IR Cut Filter
- 1.5 Lux (Color)
- 0 Lux (IR on)
- 10m IR Illumination
- Motion detection (396 zones)
- Privacy masking (396 zones)
- 2 Input/Output

TVD-M2225V-2-P

2 MPX HD Indoor IR Dome ONVIF/PSIA

Technical specifications

Camera

Sensor:	2.0 MPx 1/3" Progressive Scan CMOS
Day/Night:	Motorized IR Cut Filter
IR LEDs (Range):	Yes (10m)
IP	H.264 PSIA/ONVIF
Compression/Standard:	
Maximum Resolution (@ FPS):	1600 X 1200 (12,5 FPS)
Maximum Real Time Resolution (@ FPS):	1280X 960 (25 FPS)
Dual Streaming:	Yes
Video Bit Rate:	32 Kbps to 8 Mbps, adjustable
Sensitivity:	1.5Lux (Color) 0 Lux (IR On)
S/N Ratio:	> 50 dB
Auto Exposure (shutter):	1/25s to 1/100,000s
Composite Output (BNC):	PAL, 1.0 Vp-p @ 75 ohm (NTSC Selectable)
Lens :	2.7-9mm, F1.4 Autoiris

Network

Network Protocols:	TCP/IP, HTTP, DHCP, DNS, DDNS, RTP/RTCP, PPPoE, SMTP, NTP
Ethernet/IP:	CoS 802.1 p/Q, QoS, IPv4
PoE IEEE:	802.3af

Electrical

Voltage Input:	12 VDC PoE (IEEE 802.3af)
Power Consumption:	4.5 Watts (6.5 Watts IR on)
I/O Connection:	Terminal Plug RJ45

LocalStorage

Media:	SDHC (Secure locked card slot)
Capacity:	Up to 32GB

Audio G.711

Input:	1 ch. 3.5 mm audio interface (2.0 - 2.4 Vp-p, 1 kOhm)
Output:	1 ch. 3.5 mm audio interface (Line level, 600 Ohm)
Audio Bitrate:	16Kbps

Camera Analytics

Motion Detection:	On-board 396 zones per camera
Privacy Masking:	On-board 396 zones per camera

Alarm

Alarm Input:	2
Alarm Output:	2 Form C alarm relay
I/O Connection:	Terminal Plug

Mechanical/ Environmental

Dimensions:	140 x 120 mm (5.5 x 4.7 in.)
Weight:	1.3kg (2.8lbs)
Storage Temperature:	-20 to 70°C (-4 to 158°F)
Operating Temperature:	-10°C to 60°C (14 to 140°F)
Environmental Rating:	Indoor Vandal-Resistant

PC Requirements

Intel-based PC:	1 Ghz or faster
Memory:	1 GB RAM
Operating System:	Windows® XP, Vista or 7
CGI:	Direct X 9.0 or later
Browser:	Microsoft Internet Explorer 6.0 or later

Compatible products

Category	Reference	Description
Brackets & Mounts	TVD-M2-FM	TruVision Indoor Dome, Indoor flush mount

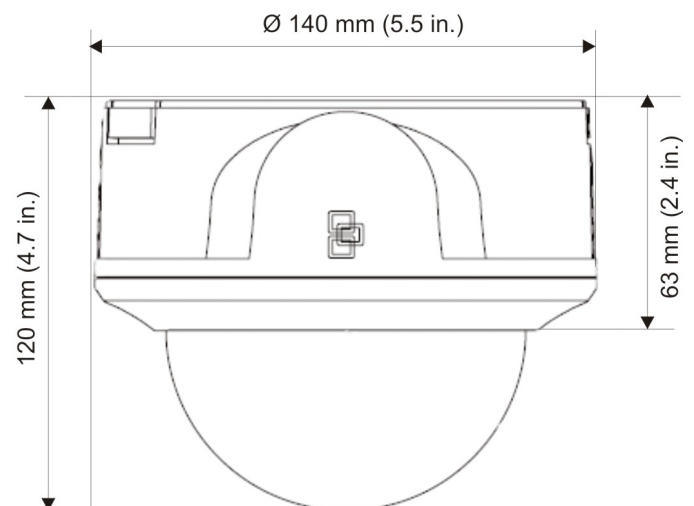

As a company of innovation, Carrier Fire & Security reserves the right to change product specifications without notice. For the latest product specifications, visit firesecurityproducts.com online or contact your sales representative.

Last updated on 12 February 2024 - 12:27